

---

**LOAD RITE** 

**ELITE SERIES**

**5 STARR SERIES**

# Trailer Operator's Manual

***IMPORTANT  
INFORMATION  
ENCLOSED***

Please read immediately!

LOAD RITE Trailers, Inc.  
265 Lincoln Highway  
Fairless Hills, PA 19030  
215-949-0500

## Table of Contents

Introduction	2
Reporting Safety Defects	3
General Specifications	4 - 7
Trailer Adjustments	7
Determining Tongue Weight	8 - 9
AB & AC (Aluminum Bunk) Trailer Set-Up	9 - 10
Operating Information & Pre-Trip Checklist	10
Troubleshooting Chart	11
Attaching Trailer to Tow Vehicle	12 - 14
Operating Your Trailer Equipped with Disc Brakes	15
Maintaining Your Trailer Equipped with Disc Brakes	16
Disc Brake Maintenance Procedure	17 - 8
Tire Safety Information	19 - 31
Vendor Warranty Contact Information	32

### **CONGRATULATIONS!**

You have purchased a truly exceptional piece of equipment. Your LOAD RITE trailer is the finest of its type, incorporating many features as standard equipment.

Your LOAD RITE trailer is designed and built to give many years of safe and satisfactory service. In addition to our design efforts, we stand ready to assist you with any problems or questions you may have regarding the normal operation and maintenance of your new trailer. Because we are a leading manufacturer, your dealer has ready access to replacement parts, technical advice and prompt service.

In order to establish your warranty, the warranty card must be completed and mailed at the time of purchase, or visit [www.loadrite.com](http://www.loadrite.com) and register online. For your records, fill in the same information on the opposite page. If you have any questions regarding the completion of your trailer warranty information, your dealer or LOAD RITE Customer Service will be more than happy to help you. ***Your product warranty is not in effect until it is registered with LOAD RITE's Warranty Department.***

**IMPORTANT - PLEASE READ**

Please read this manual thoroughly and completely. A basic understanding of your trailer is necessary for satisfactory and SAFE operation.

We reserve the right to change specifications, designs, or discontinue models at any time without notice and/or incurring obligations.



**Reporting Safety Defects**

If you believe that your vehicle has a defect which could cause a crash or could cause injury or death, you should immediately inform the National Highway Traffic Safety Administration (NHTSA) in addition to notifying Load Rite Trailers, Inc.

If NHTSA receives similar complaints, it may open an investigation and if it finds that a safety defect exists in a group of vehicles, it may order a recall and remedy campaign. However, NHTSA cannot become involved in individual problems between you, your dealer, or Load Rite Trailers, Inc. To contact NHTSA, you may either call the Auto Safety Hotline toll-free at 1-888-327-4236 (TTY: 1-800-424-9153) or write to: NHTSA, U.S. Department of Transportation, 1200 New Jersey SE, Washington, DC 20590. You can also obtain other information about motor vehicle safety from the Hotline.

Year \_\_\_\_\_ Model \_\_\_\_\_

Serial # (VIN) \_\_\_\_\_

Dealer \_\_\_\_\_ Purchase Date \_\_\_\_\_

# GENERAL SPECIFICATIONS

LOAD RITE is a registered member of the National Marine Manufacturers Association (NMMA) and the North American Trailer Manufacturers (NATM) association. All LOAD RITE trailers are designed and built to meet all US DOT specifications and NMMA certification.

## I. CAPACITY

Imprinted on your trailer certification plate (VIN sticker located on the front left side of your trailer) is the GVWR capacity. The GVWR represents the combined weight of the trailer and the load which it was designed to carry. The actual carrying capacity is the GVWR less the weight of the trailer. Carrying capacity includes the boat, motor, fuel and gear. ***If rated capacity is exceeded, the warranty is void.***

## II. TRAILERING COUPLINGS AND BALLS **CRITICAL ITEM!**

Trailer couplings are permanently marked with the following information:

- A. The coupler manufacturer's name or initials.
- B. Model or Part Number.
- C. Ball diameter, for which rating (GVWR) shall not exceed the gross trailer weight.

***Do not use a different size ball than indicated on the coupler.***

CLASS I COUPLER	2,000#	GVWR	1-7/8" Ball, 3/4" Shank
CLASS II COUPLER	3,500#	GVWR	2" Ball, 3/4" Shank
CLASS III COUPLER	5,000#	GVWR	2" Ball, 1" Shank
CLASS IV COUPLER	7,500#	GVWR	2-5/16" Ball, 1" Shank
	8,000#	GVWR	2" Ball (special application, stamped)
	10,000#	GVWR	2-5/16" Ball, 1-1/4" Shank
	13,000#	GVWR	2-5/16" Ball, 1-3/8" Shank

To adjust your standard non-brake coupler (Class I, II and III) to your trailer ball, simply adjust the nut on the bottom of the coupler. Couplers should be adjusted to a snug fit on the ball so that the 'play' is removed, but not over-tightened as to create wear. Class IV couplers and hydraulic brake actuators usually need no adjustments, but may require periodic greasing via the grease fitting where applicable.

Be sure the ball and hitch ratings match or exceed the gross load (GVWR, trailer weight and capacity) of your loaded trailer.

## III. SAFETY CHAINS

(Towing)

Your trailer is equipped with two towing safety chains or cables. When attaching your trailer to the tow vehicle, connect each of the safety chains or cables to a separate point on your hitch per the hitch manufacturer's instructions.

(Bow)

The bow safety chain (or cable) adjacent to the winch is an added safety feature and must be used by the operator when towing. After sliding the "S" hook through the bow eye of the boat, adjust the chain as tight as possible by securing it at the key hole slot on the winch support bracket. (If trailer has cable, it is non-adjustable)

## IV. WIRE COLOR CODE AND LIGHTS

The following wire color code function is used:

- **White** – ground
- **Brown (2)** – taillights, sidemarker lights, and clearance lights for each side of the trailer
- **Yellow** – left turn and stop light
- **Green** – right turn and stop light

- **Blue** – disc brake free-backing solenoid, to be wired into tow vehicle back up lights

The above wires each correspond with individual circuits on the tow vehicle. *Refer to your dealer, hitch installer, or local automotive repair shop to have the proper vehicle connector installed.*

To avoid trouble with the trailer lighting system, LOAD RITE recommends the following:

- A. Make certain the tow vehicle is equipped with a proper harness connection to avoid overloading circuits.
- B. During annual maintenance, remove light lenses (where applicable) and spray metal components with WD40<sup>®</sup> or apply a light coating of petroleum jelly.
- C. Always carry spare light bulbs for incandescent applications.

Tail light bulb - #1157

Marker light bulb - #194

3 light rear bar bulb - #L1895

*(DOES NOT APPLY TO LED LIGHTS)*

#### V. WINCH

LOAD RITE boat trailers are equipped with a hand winch designed for long life and trouble free launching and loading. **Periodically, the gears of your winch should be lubricated with an all-purpose grease.**

**Check the winch cable or strap for cuts or frayed fibers at each use. Replace immediately if any sign of wear is evident.**

Be sure to spool the cable or rope across the drum. To extend cable or rope life, **avoid a criss-cross overlap pattern while retrieving.**

#### VI. SECURING THE CARGO FOR TRAILERING

**Tie down the boat securely at the stern** with either belly type straps, ratcheting tie downs, or with a good line.

In addition to the winch cable or strap, use the bow safety chain or cable. **Again, do not depend on the winch line alone to secure the boat to the trailer.** Be certain that the bow is resting snugly on the bow rollers. Any loose cargo should be secured within the boat or to the deck of a flat top trailer.

#### VII. ALL BOLTS, NUTS, AND FASTENERS

Upon initial trailer inspection, and on a regular basis, **check all bolts and nuts for proper torque.**

#### VIII. BEARINGS AND HUBS

**NOTE: Check wheel bearings periodically by the following procedure:**

CAUTION - With the trailer connected to the tow vehicle on level ground, set the tow vehicle parking brake and chock the wheels.

- A. Chock the trailer wheel opposite the hub to be removed. Place chocks both in front and behind the tire.
- B. Position the service jack on the frame as near the wheel to be removed as possible.
- C. Rotate the elevated wheel and listen for any noise. If your trailer is equipped with brakes, be certain that the (drum-style) brake shoes are not dragging. Feel the wheel for any roughness in its rotation.
- D. A quiet and smooth rotation indicates that the bearings are in good shape. If a noise, grinding sound or roughness in rotation are evident, please contact your dealer for proper procedure.
- E. At this time the wheel bearing adjustment should be checked. At the factory, LOAD RITE sets the proper torque to maximize bearing life but on occasion it may be necessary to make an adjustment due to normal wear. To check if bearing adjustment is needed, grip the edge of the wheel to see if it rocks, or can move laterally. If the wheel moves at all, an adjustment is necessary.

First, remove the bearing protector or dust cap (refer to the section on bearing protectors in Section F) and the bearing retainer or cotter pin. Always replace the retainer or cotter pin. **DO NOT REUSE!** Tighten the spindle nut a little more than "finger tight" (approximately 20-24 inch pounds). When the nut is tensioned properly the wheel should rotate easily and have no end play. Reassemble in reverse of disassembling *using a new retainer or cotter pin*.

**NOTE: Bearing adjustment should be checked after the first 75 miles of service and every year after.**

F. If needed, grease hubs carefully after launch or before storage. Do not add grease when hub is cold, too much grease could damage brake shoes and hub seal.

Smaller trailers may be built with a steel dust cap or plastic bearing buddy and can only be properly lubricated by repacking by hand at the end of each season. Bearing protectors can also be added as an option.

Larger trailers are equipped with a **patented lubrication system** which incorporates an internally cored spindle and grease fitting. This allows the hubs to be easily greased without disassembly, and assures lubrication to the inner bearing. Using a high temperature NLGI #2 wheel bearing grease and a hand-operated grease gun, apply grease after each immersion of a warm hub into ambient water. This will displace any water introduced during the rapid cooling process. Lubricate each wheel periodically or before a long trip with a few pumps.

**NOTICE: It is required that once a year, each hub be removed, and the following items visually inspected and replaced if necessary: bearings, bearing races, seals and brake components. Repack with new grease and reassemble using a new cotter pin.**

**All work should be performed by a qualified mechanic.**

To remove your bearing protector or dust cap, place a piece of wood against the side of it. Carefully strike the wood with a hammer. Then place the wood on the opposite side, and re-strike. Continue this procedure until you have "walked" the protector out of the hub.

To reinstall your bearing protector or dust cap, line it up with your hub, place a block of wood over the front of the protector and carefully tap the wood with a hammer.

**NOTE:** All bearing protector caps are designed to fit tightly into the hub. Take extra care in *aligning* the protector cap with the hub.

## IX. TIRES

To determine the proper tire and rim size and capacity specified for your model, refer to your Vehicle Identification Number certification plate located on the front left side of your trailer. Recommended tire air pressure can be found on the certification plate and on the tire sidewall. **Always check tire pressures when cold. Always fill to the maximum rated cold pressure.**

Should the certification plate be damaged or otherwise illegible, the dealer or manufacturer can determine the proper tire, rim size, and pressure.

When jacking up the trailer to change tires, follow the same procedure as outlined above when checking hub bearings.

**When replacing tires, use only tires with the ST (Special Trailer) designation.**

## X. BRAKES AND ACTUATOR

**Contact local department of motor vehicle authority to determine brake requirements for the jurisdiction in which the trailer is to be registered. For safety, LOAD RITE recommends brakes on ALL axles where available.**

The brake system requires DOT 3 hydraulic brake fluid. **Check the actuator reservoir regularly.** Braking components should be thoroughly dry before storage for optimal service life. **CAUTION:** Wet brakes operate less efficiently. Use care in operating the trailer immediately after immersion while launching or loading.

## XI. FINISH

**After exposure to saltwater, wash the trailer thoroughly with freshwater at the first convenient opportunity.** After washing, air dry with a short ride. Galvanized trailers may

occasionally show a rust spot or surface discoloration. If this occurs, touch up with cold galvanizing spray paint. This product can be obtained through any LOAD RITE dealer, most paint, hardware, or marine stores. Thoroughly dry all components, especially brakes, before storage.

## TRAILER ADJUSTMENTS (Adjustable units only)

Most LOAD RITE trailers are designed to be fully adjustable. Available models are designed to adjust to most any variation in width, hull and bow design. Due to tremendous variance in boat hull designs and the universal nature of LOAD RITE designs, some compromises may have to be made to achieve the optimum fit.

*LOAD RITE trailers are adjusted to a neutral position at the factory. At the time of purchase the trailer may require adjustments to assure optimum fit of boat to trailer.*

Below is a brief list of possible adjustment options for most adjustable trailers:

### I. THE WINCH STAND ASSEMBLY

The winch stand assembly is designed to allow for two basic adjustments. The first is for height and the second is for hull position.

To adjust the height, loosen the fasteners clamping the winch support to the near vertical post. Reposition to the desired height and retighten. **Proper height is determined when the winch line is level with the bow eye of the boat. The winch line should attach to the bow eye after passing beneath the winch roller.**

To adjust for boat hull position, loosen the mounting U-bolts and slide the winch stand along the tongue, either forward or rearward until optimum bow roller to boat hull contact is achieved.

Hull position relative to the trailer is very important. This position determines where the boat will sit on the support system. If the winch stand is positioned incorrectly on the tongue, the rear support system may not be in proper contact with the hull.

### II. TONGUE WEIGHT **CRITICAL ITEM!**

Actual tongue weight can be determined using a simple scale per the diagram on page 8. The axle assemblies, spring or torsion, are attached to the main frame with U-bolts. To adjust the tongue weight loosen these u-bolts and slide the assemblies forward or backward as required. Moving the assemblies forward will decrease tongue weight. Moving the axle rearward will increase tongue weight.

**Caution: Be sure not to damage the brake line or wire harness in the process.**

**Caution: Axles should never be moved in excess of 6" in either direction without written approval from Load Rite.**

When complete, be certain the axle is perfectly perpendicular to the direction of forward travel.

Place a scale on a platform so that the tongue is about the same height as the hitch of the intended tow vehicle. The tongue and frames **must be parallel with level ground** when weighing and towing. The recommended tongue weight setting is normally as follows:

**For all trailers 2,000 lbs. and under, the tongue weight should equal 7% of the actual gross weight (GVWR).**

**For galvanized trailers over 2,000 lbs., the tongue weight should equal 5% to 7% of the actual gross weight (GVWR).**

**For aluminum trailers over 2,000 lbs., the tongue weight should equal 5% to 6% of the actual gross weight (GVWR).**

### III. ROLLER POSITIONING

Roller trailers offer a great amount of adjustability and can be made to accommodate most boats.

The cross bars, spanning across the trailer between the main frame rails, offer multiple height positions on most models. Some models may offer more than one longitudinal position along the frame. The pivot bars run parallel to the frame members and are mounted on brackets atop the cross bars. Pivot bars can be adjusted laterally to suit hull width and chine location requirements. The roller assemblies, mounted at each end of the

## DETERMINING TONGUE WEIGHT (TW)

**NOTE.** Gross trailer weight (GTW) is the **actual** weight of the trailer fully loaded (including trailer, boat, motor, fuel and accessories). Tongue weight (TW) is the downward force exerted on the hitch ball at the trailer coupler. In most cases, this should be 5 to 7 percent of GTW (refer to previous Trailer Adjustment section).

Tongue weight should be directly measured with a tongue weight scale (shown). If unavailable, tongue weights of up to 200 lbs. can be measured on a household scale by resting the trailer coupler on the scale and placing the scale on a block so that the coupler is at its normal towing height with trailer frames level and parallel to level ground. Trailer should be towed with frames level to parallel ground at all times.

For heavier tongue weights, place a household scale and a brick or block of wood of equal thickness as the scale upon blocks spaced three feet apart as shown below. Set a length of pipe on each and rest a beam across the pipes. Re-zero the scale to correct for the weight of the beam and pipe. Securely block the trailer wheels. Lower the trailer coupler on the beam as shown, one (1) foot from the brick or wood block and two (2) feet from the scale.

To obtain the actual tongue weight, multiply the scale reading by three (3). For greater tongue weights, place the scale and brick or wood block four (4) feet apart. Lower the coupler on the beam three (3) feet from the scale, then multiply the scale reading by four (4).

**IMPORTANT NOTICE - IMPROPER TONGUE WEIGHT, OR A TRAILER TOWED AT A FRAME ATTITUDE OTHER THAN LEVEL AND PARALLEL TO LEVEL GROUND, CAN LEAD TO IMPROPER TIRE WEAR AND UNSAFE TOWING CONDITIONS.**

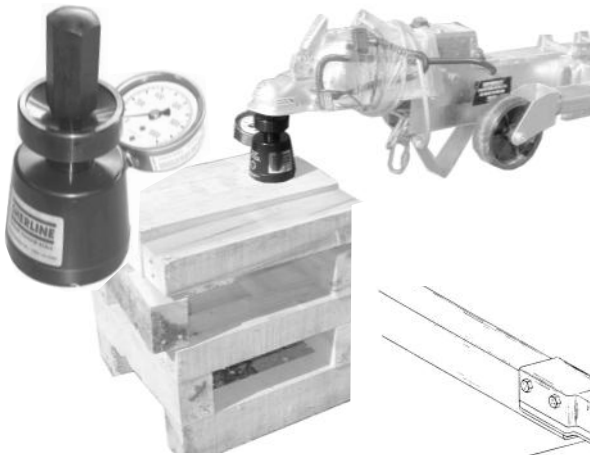

**Tongue Scale Method**  
For direct measurement to 1,000 lb.

**Tongue Weight Diagram**  
For tongue weights in excess of 200 lbs.

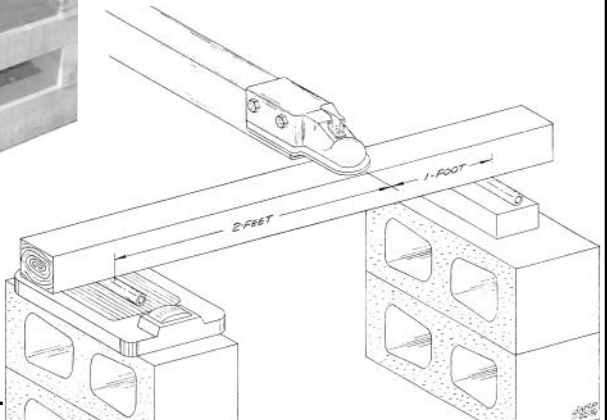

pivot bar, offer a range of adjustability, as well (on some of the smaller roller model trailers, the rollers are fixed with no adjustment).

**NOTE:** It is important to remember that boats with *longitudinal* strakes or chines should have the rollers adjusted to run on the flat area of the hull between the strakes or chines.

Also note that the rollers should be lubricated at least once a year, preferably at the start of the season, and possibly a second or third time depending on the amount of usage and water immersion. Use a dry graphite lubricant to lube the roller hub.

**CAUTION** - The boat should be removed from the trailer while ALL adjustments are being performed. **Make certain that all fasteners are properly tightened BEFORE the boat is reloaded onto the trailer.**

## AB & AC (Aluminum Bunk) Trailer Set-Up

### Step #1- Achieving proper Tongue Weight

**IMPORTANT NOTICE- PROPER TONGUE WEIGHT OF 5%-6% OF THE GVWR MUST BE OBTAINED. SINCE THE AXLES ON THE ALUMINUM TRAILERS ARE ADJUSTABLE, THERE ARE TWO METHODS TO INCREASE OR REDUCE TONGUE WEIGHT (also see \*\*\*note at bottom of this page). MAKE CERTAIN THE BOAT IS LOADED THE WAY IT WILL BE TOWED (WITH FUEL AND GEAR ON BOARD).**

When checking tongue weight always weigh at the coupler with the trailer frames in a level attitude (parallel to the ground).

**Method 1)** Position the boat on the trailer and move the boat either fore or aft to achieve proper tongue weight. The boat transom overhang should never exceed 8" past the ends of the rear bunks. Refer to boat hull manufacturer for their recommendation.

**Method 2)** Move the axles. If boat positioning (Method 1) fails to provide proper tongue weight, the axles can be re-positioned. **Never attempt to move axles with the boat on the trailer!** Mark the trailer frames before moving axles and fenders so that they are moved in the exact same amount relative to each other. Retorque ½" U-bolts (or carriage bolts) to 45-50 foot pounds when tightening. (**Do NOT over torque**).

**Caution: Be sure not to damage the brake line or wire harness in the process.**

**Caution: Axles should never be moved in excess of 6" in either direction without written approval from Load Rite.**

### Step #2- Hull set-up

1) Loosen the front target satellite or target bunks mounting bolts and lower the support all the way down. Leave bolts loose at this time.

2) Adjust main load bearing bunk centers laterally to fit boat properly. These MUST be placed as wide as possible so that proper lateral hull support is achieved. **Failure to do this could result in unsafe towing.** Avoid bunks contacting all strakes on hull.

3) Attach the trailer to the correct size tow vehicle with the ball latched and safety chains or cables properly secured to the receiver. Load the boat onto the trailer. Make certain there is adequate fender clearance and that the boat is not resting on the satellite/target bunks at this time.

**Note:** If the satellite/target bunks are taking any load at this time, then the main load bearing bunks must be raised to a higher adjustment position (*satellite/target bunk assemblies are NOT designed to support heavy loading at any time*).

4) Adjust the winch post location and support head height to match the boat bow eye.

Winch cable or strap should be parallel to the ground and pass below the winch roller.

5) Snug the satellite or target bunk assembly against the keel (maximum load = 200 lbs.)

A hydraulic bottle jack can be used. Overloading these supports can result in trailer frame damage. Tighten all bolts (1/2" straight and U-bolts to 45 ft. lbs.), and check wheel lugs 85-95 ft. lbs.

6) Attach winch cable to bow eye and pull boat firmly into bow roller (bow eye must always be below the winch roller). Attach bow safety chain and take up chain slack in the winch support keyhole.

\*\*\* Load bearing bunks can be adjusted fore & aft to help in achieving proper tongue weight

(rather than moving axles in some instances).

## OPERATING INFORMATION AND PRE-TRIP CHECKLIST

***Always tie the boat securely at the bow and stern. Do not rely solely on the winch cable/strap to secure your boat.***

### I. TOWING VEHICLE INFORMATION

Check with your marine dealer to determine the proper towing vehicle capacity for the size load to be trailered. Most vehicles require a trailer towing package. Refer to your vehicle manufacturer to determine if your tow vehicle is properly equipped for your intended use. You may also wish to have a tachometer, vacuum gauge, transmission temperature gauge and/or an engine oil gauge installed.

### II. LAUNCHING YOUR BOAT

Skill and practice will allow proper handling of a boat at the loading ramp.

Stop before reaching the ramp area, without blocking traffic, and remove any tie-downs securing the boat. Tilt the engine or drive unit up, **replace the transom drain plug**, etc. It is recommended that a safety line be attached to the boat so that it can be held in place after launching. **IMPORTANT: Do not disconnect the winch line or bow safety chain until you are at the water and ready for launch.**

Once prepared for launch, back down the ramp to the water. This will be unavoidable in most applications.

At this point, check that the safety line is clear and moved to the proper side of the boat for launching depending on ramp position. Proceed to unfasten the bow safety chain. Securely hold the winch handle, reverse the winch lock and begin unwinding the line.

Care must be taken at this time to hold the winch handle securely. *A free-spinning winch handle can be very dangerous. If the winch handle begins to free-spin, DO NOT attempt to stop it by hand.*

On an average ramp grade, the boat should gently roll back into the water. If the boat does not move, unwind 6 to 8 inches of winch line, lock the winch, and give the boat a shove. Once the boat begins to move, unlock the winch and wind the boat down into the water.

### III. LOADING AT THE RAMP

As in launching, prepare for loading before reaching the ramp. Attach the winch line to the bow eye of the boat and winch the boat onto the trailer. Never allow the winch line to unreel all the way. Always keep at least 3 turns of the cable around the drum of the winch.

On full roller trailers it is not necessary to have the boat in perfect alignment with the trailer before loading. Given sufficient time and patience, the boat should self-align as it is being winched on the trailer. Wind and water conditions can affect alignment. Connect the bow safety chain as soon as it reaches the bow hook.

Bunk type trailers are designed to load by floating the boat onto the trailer. The trailer should be submerged so that only the very front of the bunks are visible above water.

Once the boat is completely on the trailer and the bow safety chain is attached, pull the trailer away from the ramp area, and out of the way of other boat trailers.

**Proceed to fully secure the boat to the trailer before exiting the ramp parking lot. The boat should be tied down at the transom and bow, separately from the winch cable/strap.**

### IV. LOADING MISALIGNMENT

Occasionally a boat will load and be misaligned with the trailer centerline. Below is a partial list of some possible causes:

- A. Trailer rollers are not equally spaced from one side of the trailer to the other.
- B. Ramp is slanted from one side to the other. Angling trailer into the water will sometimes help this situation.
- C. Boat does not float level in the water in unloaded position.
- D. Occasionally, a boat hull is not sitting squarely on the assembly jig as it is bolted to the deck. This results in a hull with a slight twist through its longitudinal axis. This situation normally does not affect the performance characteristics of the craft.

Wind, tidal, wake, current, or other environmental conditions could float the hull off trailer center while loading.

# BRAKE TROUBLESHOOTING

## A. Excessive travel in actuator mechanism:

### Possible cause:

Low fluid in master cylinder reservoir; air in hydraulic lines.

Leaking primary cup in master cylinder; ports closed or restricted with dirt; defective hoses; leaking check valve fails to hold hydraulic pressure.

Excessive lining-to-drum clearance.

Leaks in hydraulic lines.

### Corrective action:

Refill master cylinder and bleed system.

Check all components and make corrections required.

Adjust brakes (drum) or replace linings.

Replace defective lines.

## B. Pressure build-up in hydraulic system:

### Possible cause:

Master cylinder piston fails to stop, keeping compensating port closed.

Contaminated fluid causing rubber cups to swell.

Hose cylinder ports closed or restricted with dirt, or weak return spring.

Back up solenoid stuck or inoperative

### Corrective action:

See Authorized Dealer.

Drain, flush and replace fluid, replace cups and rubber hoses.

Overhaul or replace.

Repair or replace as necessary.

## C. Brake noise

### Possible cause:

Worn or cracked drum or rotor machined beyond allowable oversize limits.

Vibration with loose bolts, out-of-round drum or rotor.

Shoe/pad clatter, lining coated with grease.

Vibration with loose bearing adjustment or rough bearing action.

### Corrective action:

Replace drum or rotor.

Tighten hub bolts, recondition or replace drum or rotor.

Correct cause of grease leakage, reline and grind for proper contact.

Adjust and lubricate bearings or replace.

## D. Brakes lock in reverse

### Possible cause:

Inoperative solenoid (disc brake)

Out of adjustment (drum brake)

### Corrective action:

Check trailer to tow vehicle connection, check electrical signal. Replace solenoid.

Adjust linings

## PROPERLY ATTACHING YOUR TRAILER TO THE TOW VEHICLE

### Mechanical attachment of your trailer to the tow vehicle

Depending upon capacity, your trailer is equipped with a coupler that accepts either a 2" or 2-5/16" diameter tow ball with a centerline 18" to 21" from the ground. The coupler is clearly marked for this requirement. Make certain your tow vehicle is properly equipped and set up. Once attached, trailer frame should be parallel to level ground.

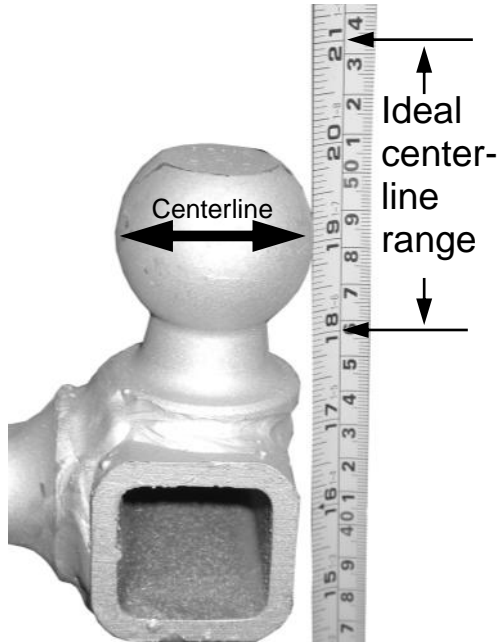

## ***Activate your Load Rite Warranty***

Visit [www.loadrite.com](http://www.loadrite.com) to register your warranty with Load Rite.

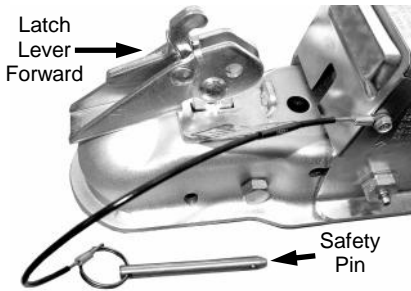

**Actuator - Latch Open**

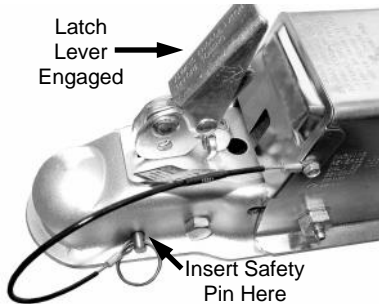

**Actuator - Latch Engaged**

Attach the safety cables from the trailer to their proper and respective attachment points on the tow vehicle. Make certain the quick-link fasteners are properly positioned and completely tightened. Attach the safety brake activation cable from the actuator to the tow vehicle adjacent to one of the quick links.

Your trailer should now be properly and safely mechanically attached to your tow vehicle. Proceed to electrical system attachment.

Once you are certain that your tow vehicle is equipped with a properly sized, rated, and positioned ball, raise the trailer on the tongue jack so that the ball of the tow vehicle can be maneuvered directly beneath the ball socket of the actuator. Remove any safety lock pins from the actuator lever and move the lever to the forward position. Crank the handle of the tongue jack and lower the actuator socket over the tow vehicle ball. Once you are certain the actuator is fully seated on the ball, move the latch to the engaged position and insert the safety pin through the actuator slider in the hole located directly behind the ball socket. Continue to lower the tongue jack to its fully retracted position. Rotate the jack to its horizontal position for travel.

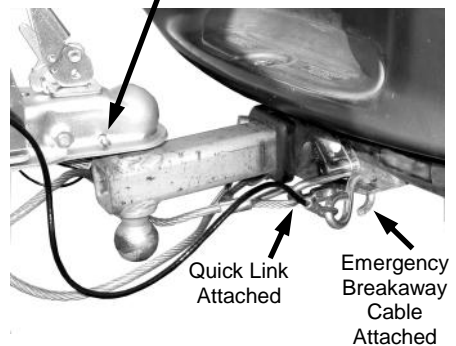
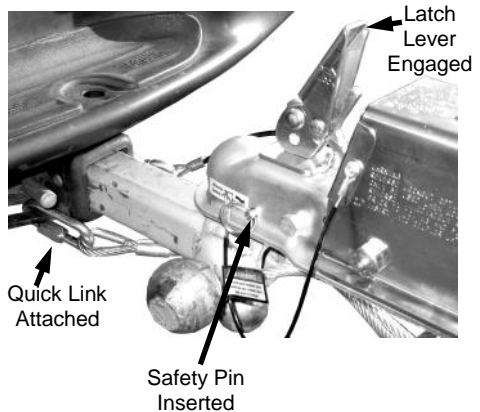

**Properly Attached Trailer**

# Attaching the trailer electrical system to the tow vehicle

Your trailer is equipped with a six-wire, five-connector wiring harness. The colors function as follows:

- **White** – ground
- **Brown** (2) – taillights, sidemarkers lights, and clearance lights for each side of the trailer
- **Yellow** – left turn and stop light
- **Green** – right turn and stop light
- **Blue** – disc brake free-backing solenoid, to be wired into tow vehicle back up lights

The above wires each correspond with individual circuits on the tow vehicle. Refer to your dealer, hitch installer, or local automotive repair shop to have the proper vehicle connector installed.

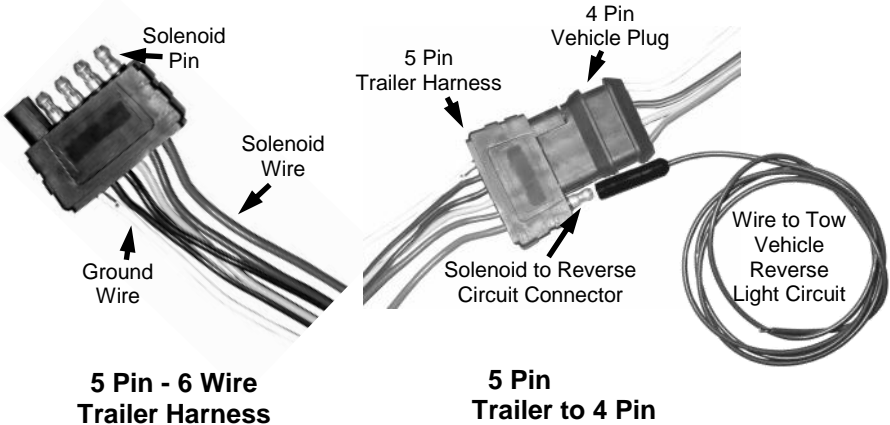

If your tow vehicle is equipped with a five-wire, four-connector harness, it will be necessary to retrofit the vehicle with the proper connector. Alternatively, the five-wire four-connector tow vehicle harness can be used with the six-wire five-connector harness. If the trailer is equipped with disc brakes, the exposed terminal must be wired to the reverse light circuit of the tow vehicle for proper brake operation while backing the rig.



Models equipped with electric or electric over hydraulic brakes are equipped with a 7-round plug.

## OPERATING YOUR TRAILER EQUIPPED WITH DISC BRAKES

The disc brakes on your trailer function under the surge principle. As the tow vehicle brakes are applied, the trailer pushes, or “surges”, against the tow ball. This action generates pressure in the trailer hydraulic system and causes the brake calipers to squeeze the brake pads and grip the rotors.

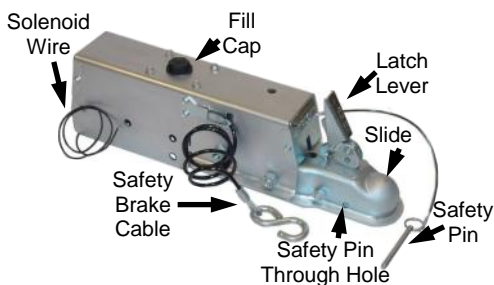

light circuit on the tow vehicle and the vehicle gear selector in reverse position, the actuator free-reverse solenoid is energized. When energized, the solenoid bleeds all hydraulic line pressure and fluid flows directly to the actuator master cylinder reservoir. The wheels then rotate freely in reverse.

***CHECK FLUID LEVEL***  
Remove the fill cap and check the brake fluid level at each use.

**Always top off with DOT 3 brake fluid as needed.**

While operating the vehicle in reverse, pressure is applied to the trailer hydraulic system as the tow ball pushes back on the actuator. With the solenoid wire properly attached to the reverse

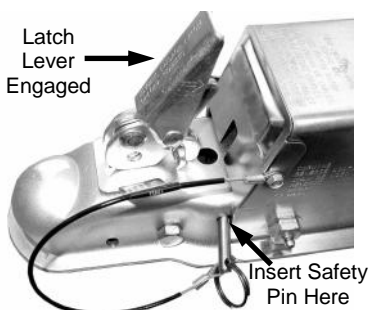

**Actuator - Emergency Backup Engaged**

### ***IMPORTANT SAFETY NOTE***

Once properly wired, the tow vehicle/trailer rig may be safely operated on the highway.

**In an emergency**, the trailer may be jockeyed about the yard or ramp by any vehicle through utilizing the tethered lock pin placed in the left side of the actuator inner slide adjacent to the fixed housing. This hole does not go through both sides of the slide. **This feature is for emergency trailer movement only, and is not designed to supplant use of the solenoid system under roadway operation.**

**WARNING** - LOAD RITE RECOMMENDS THAT ALL MAINTENANCE BE PERFORMED BY A QUALIFIED MECHANIC.

## MAINTAINING YOUR TRAILER EQUIPPED WITH DISC BRAKES

The disc brakes on your trailer have been engineered for the rigorous duty of a marine environment. Like any mechanical system, the disc brakes on your trailer require periodic inspection and preventive maintenance.

LOAD RITE recommends brake system service be performed annually for optimum, reliable system performance. The end of the season is the ideal time to perform preventive maintenance on your trailer.

### Annual Hub and Disc Brake Maintenance Overview

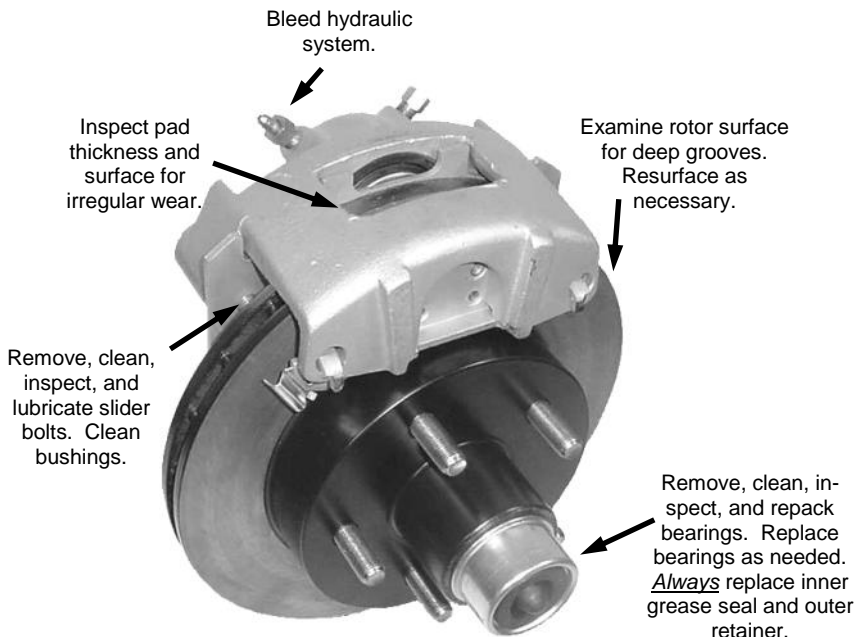

### ***REGULAR MAINTENANCE NOTE***

Add grease easily at any time by removing the rubber grommet on the bearing cover and exposing the standard grease fitting.

To prevent inopportune maintenance problems, LOAD RITE recommends you grease this way after each water immersion.

**WARNING - LOAD RITE RECOMMENDS THAT ALL MAINTENANCE BE PERFORMED BY A QUALIFIED MECHANIC.**

## ***IMPORTANT SAFETY NOTE***

**Never raise a trailer wheel off the ground for service unless the trailer is safely attached to the tow vehicle, and one wheel on each side of the trailer is fully chocked.**

## **DISC BRAKE MAINTENANCE PROCEDURE**

**Work on only one wheel at a time.** Begin by removing the wheel and visually inspecting brake pad thickness. This will help indicate the amount of remaining pad life. Note that the inner and outer pads at each wheel are of differing thicknesses from the factory. Examine the faces of each rotor for signs of uneven wear. Run a fingernail across each face. If this test indicates ridges or other imperfections exist in the rotor face, you may want to consider having the rotors resurfaced. Resurface the rotors in pairs and always replace the pads when resurfacing the rotors.

Remove the bolts securing the caliper to the

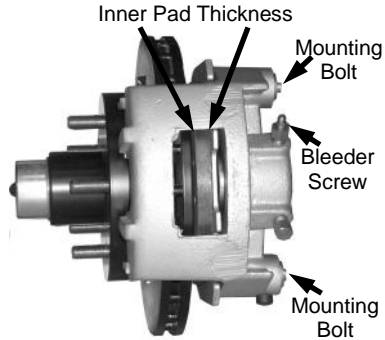

mounting bracket. Inspect the face of the brake pad in the same way you inspected the rotor. Replace the pads if there are any surface irregularities or if the pads have  $3/32$ " or less material from the surface to the most shallow rivet. If one pad needs replacement, always replace all of the pads on the same axle. Always resurface the rotors when replacing the pads.

Secure the caliper to the frame and out of the way of the rotor with a zip tie or bungee cord. ***Do not allow the caliper to hang from the brake hose!***

Remove the outer bearing protector. Remove the locking mechanism and large outer nut from the spindle.

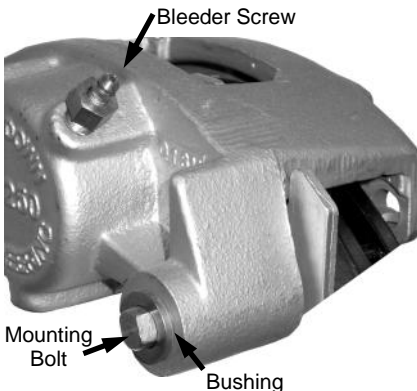

Carefully remove the rotor (or hub) from the spindle taking care to prevent the outer bearing from falling out of the hub assembly. Remove the outer bearing and set aside. Invert the hub assembly so the inner seal is visible. Remove the inner seal and discard. Replace with a new seal at reassembly. Remove the inner bearing and set aside.

Wipe each bearing with a clean cloth. Be careful to remove all excess and contaminated lubricant. Wipe the spindle clean with a clean cloth. Examine all bearing and spindle surfaces for discoloration or pitting. If evidence of either, replace all affected components. In the case of evidence of water contamination, replace all bearings and seals immediately.

Pack each bearing with high-temperature lithium based NLGI #2 wheel bearing grease. Reassemble in the reverse order of disassembly. *Remember to install a new seal and a new spindle nut locking device.*

***SERVICE NOTE***

***Always*** replace these items at each hub service! Retainer design may vary by model.

Inner Seal      Outer Retainer  
Cotter Pin Retainer



**DISC BRAKES**

Reinstall the caliper over the rotor and secure with the stainless mounting bolts. Apply blue Loctite to the threads of the slider bolts. Torque to 20 lb. ft. if coarse threads, 35 - 40 lb. ft. if fine thread.

Install the wheel. While rotating the wheel, torque the spindle nut to 20 lb. ft. Loosen ¼ turn and retighten by hand until snug. Securely fit the spindle nut locking device.

Torque the wheel lugs to 80 – 95 lb. ft. Repeat all of the above for each wheel on your trailer.

***IMPORTANT - BLEED YOUR BRAKES***

Bleeding the brake hydraulic system at each caliper should be part of **annual trailer maintenance**. Brake fluid absorbs moisture and becomes ineffective at converting hydraulic pressure to braking action. *It is possible for the brakes to become ineffective or even lock during operation if the fluid is not serviced annually.*

# TIRE SAFETY INFORMATION

## 1.1. Tire Safety Information

This portion of the User's Manual contains tire safety information as required by 49 CFR 575.6.

Section 2.1 contains "Steps for Determining Correct Load Limit - Trailer".

Section 2.2 contains "Steps for Determining Correct Load Limit – Tow Vehicle".

Section 2.3 contains a Glossary of Tire Terminology, including "cold inflation pressure", "maximum inflation pressure", "recommended inflation pressure", and other non-technical terms.

Section 2.4 contains information from the NHTSA brochure entitled "Tire Safety – Everything Rides On It".

This brochure, as well as the preceding subsections, describes the following items;

- Tire labeling, including a description and explanation of each marking on the tires, and information about the DOT Tire Identification Number (TIN).
  - Recommended tire inflation pressure, including a description and explanation of:
    - A. Cold inflation pressure.
    - B. Vehicle Placard and location on the vehicle.
    - C. Adverse safety consequences of under inflation (including tire failure).
    - D. Measuring and adjusting air pressure for proper inflation.
  - Tire Care, including maintenance and safety practices.
  - Vehicle load limits, including a description and explanation of the following items:
    - A. Locating and understanding the load limit information, total load capacity, and cargo capacity.
    - B. Calculating total and cargo capacities with varying seating configurations including quantitative examples showing / illustrating how the vehicles cargo and luggage capacity decreases as combined number and size of occupants' increases. This item is also discussed in Section 3.
    - C. Determining compatibility of tire and vehicle load capabilities.
    - D. Adverse safety consequences of overloading on handling and stopping on tires.

## 1.2. Steps for Determining Correct Load Limit – Trailer

Determining the load limits of a trailer includes more than understanding the load limits of the tires alone. On all trailers there is a Federal certification/VIN label that is located on the forward half of the left (road) side of the unit. This certification/VIN label will indicate the trailer's Gross Vehicle Weight Rating (GVWR). This is the most weight the fully loaded trailer can weigh. It will also provide the Gross Axle Weight Rating (GAWR). This is the most a particular axle can weigh. If there are multiple axles, the GAWR of each axle will be provided.

If your trailer has a GVWR of 10,000 pounds or less, there is a vehicle placard located in the same location as the certification label described above. This placard provides tire and loading information. In addition, this placard will show a statement regarding maximum cargo capacity. Cargo can be added to the trailer, up to the maximum weight specified on the placard. The combined weight of the cargo is provided as a single

number. In any case, remember: the total weight of a fully loaded trailer can not exceed the stated GVWR.

For trailers with living quarters installed, the weight of water and propane also need to be considered. The weight of fully filled propane containers is considered part of the weight of the trailer before it is loaded with cargo, and is not considered part of the disposable cargo load. Water however, is a disposable cargo weight and is treated as such. If there is a fresh water storage tank of 100 gallons, this tank when filled would weigh about 800 pounds. If more cargo is being transported, water can be off-loaded to keep the total amount of cargo added to the vehicle within the limits of the GVWR so as not to overload the vehicle. Understanding this flexibility will allow you, the owner, to make choices that fit your travel needs.

When loading your cargo, be sure it is distributed evenly to prevent overloading front to back and side to side. Heavy items should be placed low and as close to the axle positions as reasonable. Too many items on one side may overload a tire. The best way to know the actual weight of the vehicle is to weigh it at a public scale. Talk to your dealer to discuss the weighing methods needed to capture the various weights related to the trailer. This would include the weight empty or unloaded, weights per axle, wheel, hitch or king-pin, and total weight.

Excessive loads and/or underinflation cause tire overloading and, as a result, abnormal tire flexing occurs. This situation can generate an excessive amount of heat within the tire. Excessive heat may lead to tire failure. It is the air pressure that enables a tire to support the load, so proper inflation is critical. The proper air pressure may be found on the certification/VIN label and/or on the Tire Placard. This value should never exceed the maximum cold inflation pressure stamped on the tire.

### 1.2.1. Trailers 10,000 Pounds GVWR or Less

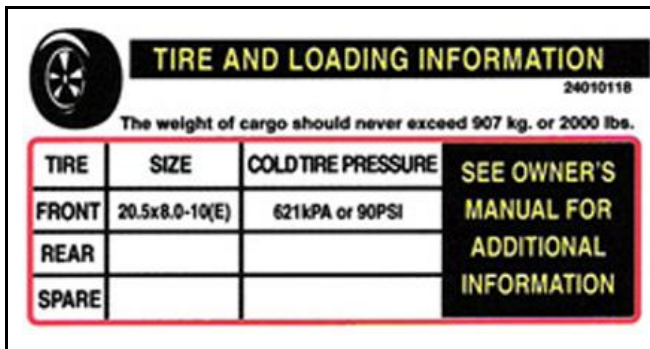

## Tire and Loading Information Placard – Figure 1-1

1. Locate the statement, “The weight of cargo should never exceed XXX kg or XXX lbs.,” on your vehicle’s placard. See figure 1-1.
2. This figure equals the available amount of cargo and luggage load capacity.
3. Determine the combined weight of luggage and cargo being loaded on the vehicle. That weight may not safely exceed the available cargo and luggage load capacity.

The trailer’s placard refers to the Tire Information Placard attached adjacent to or near the trailer’s VIN (Certification) label at the left front of the trailer.

### 1.2.2. Trailers Over 10,000 Pounds GVWR (Note: These trailers are not required to have a tire information placard on the vehicle)

Determine the empty weight of your trailer by weighing the trailer using a public scale or other means. This step does not have to be repeated.

Locate the GVWR (Gross Vehicle Weight Rating) of the trailer on your trailer’s VIN (Certification) label.

Subtract the empty weight of your trailer from the GVWR stated on the VIN label. That weight is the maximum available cargo capacity of the trailer and may not be safely exceeded.

### **1.3. Steps for Determining Correct Load Limit – Tow Vehicle**

1. Locate the statement, “The combined weight of occupants and cargo should never exceed XXX lbs.,” on your vehicle’s placard.
2. Determine the combined weight of the driver and passengers who will be riding in your vehicle.
3. Subtract the combined weight of the driver and passengers from XXX kilograms or XXX pounds.
4. The resulting figure equals the available amount of cargo and luggage capacity. For example, if the “XXX” amount equals 1400 lbs. and there will be five 150 lb. passengers in your vehicle, the amount of available cargo and luggage capacity is 650 lbs. (1400-750 (5 x 150) = 650 lbs.).
5. Determine the combined weight of luggage and cargo being loaded on the vehicle. That weight may not safely exceed the available cargo and luggage capacity calculated in Step # 4.
6. If your vehicle will be towing a trailer, load from your trailer will be transferred to your vehicle. Consult the tow vehicle’s manual to determine how this weight transfer reduces the available cargo and luggage capacity of your vehicle.

### **1.4. Glossary Of Tire Terminology**

#### **Accessory weight**

The combined weight (in excess of those standard items which may be replaced) of automatic transmission, power steering, power brakes, power windows, power seats, radio and heater, to the extent that these items are available as factory-installed equipment (whether installed or not).

#### **Bead**

The part of the tire that is made of steel wires, wrapped or reinforced by ply cords and that is shaped to fit the rim.

#### **Bead separation**

This is the breakdown of the bond between components in the bead.

#### **Bias ply tire**

A pneumatic tire in which the ply cords that extend to the beads are laid at alternate angles substantially less than 90 degrees to the centerline of the tread.

#### **Carcass**

The tire structure, except tread and sidewall rubber which, when inflated, bears the load.

#### **Chunking**

The breaking away of pieces of the tread or sidewall.

#### **Cold inflation pressure**

The pressure in the tire before you drive.

#### **Cord**

The strands forming the plies in the tire.

#### **Cord separation**

The parting of cords from adjacent rubber compounds.

#### **Cracking**

Any parting within the tread, sidewall, or inner liner of the tire extending to cord material.

#### **CT**

A pneumatic tire with an inverted flange tire and rim system in which the rim is designed with rim flanges pointed radially inward and the tire is designed to fit on the underside of the rim in

a manner that encloses the rim flanges inside the air cavity of the tire.

**Curb weight**

The weight of a motor vehicle with standard equipment including the maximum capacity of fuel, oil, and coolant, and, if so equipped, air conditioning and additional weight optional engine.

**Extra load tire**

A tire designed to operate at higher loads and at higher inflation pressures than the corresponding standard tire.

**Groove**

The space between two adjacent tread ribs.

**Gross Axle Weight Rating**

The maximum weight that any axle can support, as published on the Certification / VIN label on the front left side of the trailer. Actual weight determined by weighing each axle on a public scale, with the trailer attached to the towing vehicle.

**Gross Vehicle Weight Rating**

The maximum weight of the fully loaded trailer, as published on the Certification / VIN label. Actual weight determined by weighing trailer on a public scale, without being attached to the towing vehicle.

**Hitch Weight**

The downward force exerted on the hitch ball by the trailer coupler.

**Innerliner**

The layer(s) forming the inside surface of a tubeless tire that contains the inflating medium within the tire.

**Innerliner separation**

The parting of the innerliner from cord material in the carcass.

**Intended outboard sidewall**

The sidewall that contains a white-wall, bears white lettering or bears manufacturer, brand, and/or model name molding that is higher or deeper than the same molding on the other sidewall of the tire or the outward facing sidewall of an asymmetrical tire that has a particular side that must always face outward when mounted on a vehicle.

**Light truck (LT) tire**

A tire designated by its manufacturer as primarily intended for use on lightweight trucks or multipurpose passenger vehicles.

**Load rating**

The maximum load that a tire is rated to carry for a given inflation pressure.

**Maximum load rating**

The load rating for a tire at the maximum permissible inflation pressure for that tire.

**Maximum permissible inflation pressure**

The maximum cold inflation pressure to which a tire may be inflated.

**Maximum loaded vehicle weight**

The sum of curb weight, accessory weight, vehicle capacity weight, and production options weight.

**Measuring rim**

The rim on which a tire is fitted for physical dimension requirements.

**Pin Weight**

The downward force applied to the 5<sup>th</sup> wheel or gooseneck ball, by the trailer kingpin or gooseneck coupler.

**Non-pneumatic rim**

A mechanical device which, when a non-pneumatic tire assembly incorporates a wheel, supports the tire, and attaches, either integrally or separately, to the wheel center member and upon which the tire is attached.

**Non-pneumatic spare tire assembly**

A non-pneumatic tire assembly intended for temporary use in place of one of the pneumatic tires and rims that are fitted to a passenger car in compliance with the requirements of this standard.

**Non-pneumatic tire**

A mechanical device which transmits, either directly or through a wheel or wheel center member, the vertical load and tractive forces from the roadway to the vehicle, generates the tractive forces that provide the directional control of the vehicle and does not rely on the containment of any gas or fluid for providing those functions.

**Non-pneumatic tire assembly**

A non-pneumatic tire, alone or in combination with a wheel or wheel center member, which can be mounted on a vehicle.

**Normal occupant weight**

This means 68 kilograms (150 lbs.) times the number of occupants specified in the second column of Table I of 49 CFR 571.110.

**Occupant distribution**

The distribution of occupants in a vehicle as specified in the third column of Table I of 49 CFR 571.110.

**Open splice**

Any parting at any junction of tread, sidewall, or innerliner that extends to cord material.

**Outer diameter**

The overall diameter of an inflated new tire.

**Overall width**

The linear distance between the exteriors of the sidewalls of an inflated tire, including elevations due to labeling, decorations, or protective bands or ribs.

**Ply**

A layer of rubber-coated parallel cords.

**Ply separation**

A parting of rubber compound between adjacent plies.

**Pneumatic tire**

A mechanical device made of rubber, chemicals, fabric and steel or other materials, that, when mounted on an automotive wheel, provides the traction and contains the gas or fluid that sustains the load.

**Production options weight**

The combined weight of those installed regular production options weighing over 2.3 kilograms (5 lbs.) in excess of those standard items which they replace, not previously considered in curb

weight or accessory weight, including heavy duty brakes, ride levelers, roof rack, heavy duty battery, and special trim.

**Radial ply tire**

A pneumatic tire in which the ply cords that extend to the beads are laid at substantially 90 degrees to the centerline of the tread.

**Recommended inflation pressure**

This is the inflation pressure provided by the vehicle manufacturer on the Tire Information label and on the Certification / VIN tag.

**Reinforced tire**

A tire designed to operate at higher loads and at higher inflation pressures than the corresponding standard tire.

**Rim**

A metal support for a tire or a tire and tube assembly upon which the tire beads are seated.

**Rim diameter**

This means the nominal diameter of the bead seat.

**Rim size designation**

This means the rim diameter and width.

**Rim type designation**

This means the industry of manufacturer's designation for a rim by style or code.

**Rim width**

This means the nominal distance between rim flanges.

**Section width**

The linear distance between the exteriors of the sidewalls of an inflated tire, excluding elevations due to labeling, decoration, or protective bands.

**Sidewall**

That portion of a tire between the tread and bead.

**Sidewall separation**

The parting of the rubber compound from the cord material in the sidewall.

**Special Trailer (ST) tire**

The "ST" is an indication the tire is for trailer use only.

**Test rim**

The rim on which a tire is fitted for testing, and may be any rim listed as appropriate for use with that tire.

**Tread**

That portion of a tire that comes into contact with the road.

**Tread rib**

A tread section running circumferentially around a tire.

**Tread separation**

Pulling away of the tread from the tire carcass.

**Treadwear indicators (TWI)**

The projections within the principal grooves designed to give a visual indication of the degrees

of wear of the tread.

### **Vehicle capacity weight**

The rated cargo and luggage load plus 68 kilograms (150 lbs.) times the vehicle's designated seating capacity.

### **Vehicle maximum load on the tire**

The load on an individual tire that is determined by distributing to each axle its share of the maximum loaded vehicle weight and dividing by two.

### **Vehicle normal load on the tire**

The load on an individual tire that is determined by distributing to each axle its share of the curb weight, accessory weight, and normal occupant weight (distributed in accordance with Table I of CRF 49 571.110) and dividing by 2.

### **Weather side**

The surface area of the rim not covered by the inflated tire.

### **Wheel center member**

In the case of a non-pneumatic tire assembly incorporating a wheel, a mechanical device which attaches, either integrally or separably, to the non-pneumatic rim and provides the connection between the non-pneumatic rim and the vehicle; or, in the case of a non-pneumatic tire assembly not incorporating a wheel, a mechanical device which attaches, either integrally or separably, to the non-pneumatic tire and provides the connection between tire and the vehicle.

### **Wheel-holding fixture**

The fixture used to hold the wheel and tire assembly securely during testing.

## **1.5. Tire Safety - Everything Rides On It**

The National Traffic Safety Administration (NHTSA) has published a brochure (DOT HS 809 361) that discusses all aspects of Tire Safety, as required by CFR 575.6. This brochure is reproduced in part below. It can be obtained and downloaded from NHTSA, free of charge, from the following web site:

[http://www.nhtsa.dot.gov/cars/rules/TireSafety/ridesonit/tires\\_index.html](http://www.nhtsa.dot.gov/cars/rules/TireSafety/ridesonit/tires_index.html)

Studies of tire safety show that maintaining proper tire pressure, observing tire and vehicle load limits (not carrying more weight in your vehicle than your tires or vehicle can safely handle), avoiding road hazards, and inspecting tires for cuts, slashes, and other irregularities are the most important things you can do to avoid tire failure, such as tread separation or blowout and flat tires. These actions, along with other care and maintenance activities, can also:

- Improve vehicle handling
- Help protect you and others from avoidable breakdowns and accidents
- Improve fuel economy
- Increase the life of your tires.

This booklet presents a comprehensive overview of tire safety, including information on the following topics:

- Basic tire maintenance
- Uniform Tire Quality Grading System
- Fundamental characteristics of tires
- Tire safety tips.

Use this information to make tire safety a regular part of your vehicle maintenance routine.

Recognize that the time you spend is minimal compared with the inconvenience and safety consequences of a flat tire or other tire failure.

### **1.6. Safety First—Basic Tire Maintenance**

Properly maintained tires improve the steering, stopping, traction, and load-carrying capability of your vehicle. Underinflated tires and overloaded vehicles are a major cause of tire failure. Therefore, as mentioned above, to avoid flat tires and other types of tire failure, you should maintain proper tire pressure, observe tire and vehicle load limits, avoid road hazards, and regularly inspect your tires.

#### **1.6.1. Finding Your Vehicle's Recommended Tire Pressure and Load Limits**

Tire information placards and vehicle certification labels contain information on tires and load limits. These labels indicate the vehicle manufacturer's information including:

- Recommended tire size
- Recommended tire inflation pressure
- Vehicle capacity weight (VCW—the maximum occupant and cargo weight a vehicle is designed to carry)
- Front and rear gross axle weight ratings (GAWR—the maximum weight the axle systems are designed to carry).

Both placards and certification labels are permanently attached to the trailer near the left front.

#### **1.6.2. Understanding Tire Pressure and Load Limits**

Tire inflation pressure is the level of air in the tire that provides it with load-carrying capacity and affects the overall performance of the vehicle. The tire inflation pressure is a number that indicates the amount of air pressure—measured in pounds per square inch (psi)—a tire requires to be properly inflated. (You will also find this number on the vehicle information placard expressed in kilopascals (kpa), which is the metric measure used internationally.)

Manufacturers of passenger vehicles and light trucks determine this number based on the vehicle's design load limit, that is, the greatest amount of weight a vehicle can safely carry and the vehicle's tire size. The proper tire pressure for your vehicle is referred to as the "recommended cold inflation pressure." (As you will read below, it is difficult to obtain the recommended tire pressure if your tires are not cold.)

Because tires are designed to be used on more than one type of vehicle, tire manufacturers list the "maximum permissible inflation pressure" on the tire sidewall. This number is the greatest amount of air pressure that should ever be put in the tire under normal driving conditions.

#### **1.6.3. Checking Tire Pressure**

It is important to check your vehicle's tire pressure at least once a month for the following reasons:

- Most tires may naturally lose air over time.
- Tires can lose air suddenly if you drive over a pothole or other object or if you strike the curb when parking.
- With radial tires, it is usually not possible to determine underinflation by visual inspection.

For convenience, purchase a tire pressure gauge to keep in your vehicle. Gauges can be purchased at tire dealerships, auto supply stores, and other retail outlets.

The recommended tire inflation pressure that vehicle manufacturers provide reflects the proper psi when a tire is cold. The term cold does not relate to the outside temperature. Rather, a cold tire is one that has not been driven on for at least three hours. When you drive, your tires get warmer, causing the air pressure within them to increase. Therefore, to get an accurate tire pressure reading, you must measure tire pressure when the tires are cold or compensate for the extra pressure in warm tires.

### **1.6.4. Steps for Maintaining Proper Tire Pressure**

- Step 1: Locate the recommended tire pressure on the vehicle's tire information placard, certification label, or in the owner's manual.
- Step 2: Record the tire pressure of all tires.
- Step 3: If the tire pressure is too high in any of the tires, slowly release air by gently pressing on the tire valve stem with the edge of your tire gauge until you get to the correct pressure.
- Step 4: If the tire pressure is too low, note the difference between the measured tire pressure and the correct tire pressure. These "missing" pounds of pressure are what you will need to add.
- Step 5: At a service station, add the missing pounds of air pressure to each tire that is underinflated.
- Step 6: Check all the tires to make sure they have the same air pressure (except in cases in which the front and rear tires are supposed to have different amounts of pressure).

If you have been driving your vehicle and think that a tire is underinflated, fill it to the recommended cold inflation pressure indicated on your vehicle's tire information placard or certification label. While your tire may still be slightly underinflated due to the extra pounds of pressure in the warm tire, it is safer to drive with air pressure that is slightly lower than the vehicle manufacturer's recommended cold inflation pressure than to drive with a significantly underinflated tire. Since this is a temporary fix, don't forget to recheck and adjust the tire's pressure when you can obtain a cold reading.

### **1.6.5. Tire Size**

To maintain tire safety, purchase new tires that are the same size as the vehicle's original tires or another size recommended by the manufacturer. Look at the tire information placard, the owner's manual, or the sidewall of the tire you are replacing to find this information. If you have any doubt about the correct size to choose, consult with the tire dealer.

### **1.6.6. Tire Tread**

The tire tread provides the gripping action and traction that prevent your vehicle from slipping or sliding, especially when the road is wet or icy. In general, tires are not safe and should be replaced when the tread is worn down to 1/16 of an inch. Tires have built-in treadwear indicators that let you know when it is time to replace your tires. These indicators are raised sections spaced intermittently in the bottom of the tread grooves. When they appear "even" with the outside of the tread, it is time to replace your tires. Another method for checking tread depth is to place a penny in the tread with Lincoln's head upside down and facing you. If you can see the top of Lincoln's head, you are ready for new tires.

### **1.6.7. Tire Balance and Wheel Alignment**

To avoid vibration or shaking of the vehicle when a tire rotates, the tire must be properly balanced. This balance is achieved by positioning weights on the wheel to counterbalance heavy spots on the wheel-and-tire assembly. A wheel alignment adjusts the angles of the wheels so that they are positioned correctly relative to the vehicle's frame. This adjustment maximizes the life of your tires. These adjustments require special equipment and should be performed by a qualified technician.

### **1.6.8. Tire Repair**

The proper repair of a punctured tire requires a plug for the hole and a patch for the area inside the tire that surrounds the puncture hole. Punctures through the tread can be repaired if they are not too large, but punctures to the sidewall should not be repaired. Tires must be removed from the rim to be properly inspected before being plugged and patched.

### **1.6.9. Tire Fundamentals**

Federal law requires tire manufacturers to place standardized information on the sidewall of all tires. This information identifies and describes the fundamental characteristics of the tire and also provides a tire identification number for safety standard certification and in case of a recall.

### 1.6.9.1. Information on Passenger Vehicle Tires

Please refer to the diagram below.

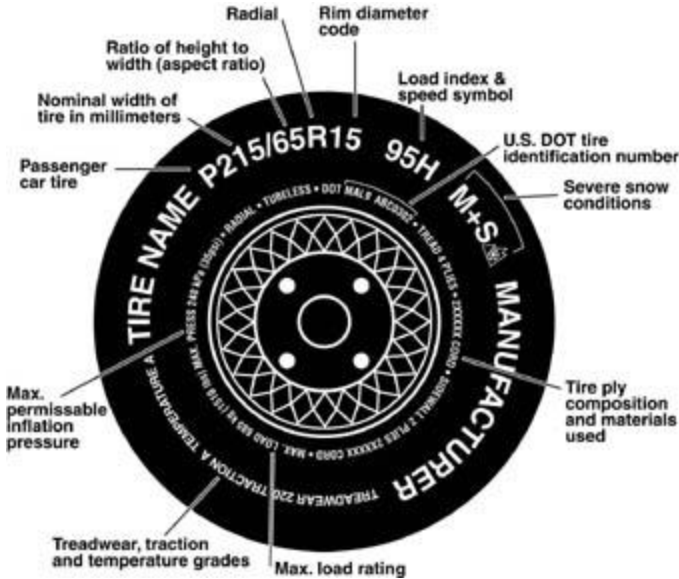

#### **P**

The "P" indicates the tire is for passenger vehicles.  
(Trailer tires will carry the "ST" indication, for Special Trailer service.)

#### **Next number**

This three-digit number gives the width in millimeters of the tire from sidewall edge to sidewall edge. In general, the larger the number, the wider the tire.

#### **Next number**

This two-digit number, known as the aspect ratio, gives the tire's ratio of height to width. Numbers of 70 or lower indicate a short sidewall for improved steering response and better overall handling on dry pavement.

#### **R**

The "R" stands for radial. Radial ply construction of tires has been the industry standard for the past 20 years.

#### **Next number**

This two-digit number is the wheel or rim diameter in inches. If you change your wheel size, you will have to purchase new tires to match the new wheel diameter.

#### **Next number**

This two- or three-digit number is the tire's load index. It is a measurement of how much weight each tire can support. You may find this information in your owner's manual. If not, contact a local tire dealer. Note: You may not find this information on all tires because it is not required by law.

#### **M+S**

The "M+S" or "M/S" indicates that the tire has some mud and snow capability. Most radial tires have these markings; hence, they have some mud and snow capability.

Letter Rating	Speed Rating
Q	99 mph
R	106 mph
S	112 mph
T	118 mph
U	124 mph
H	130 mph
V	149 mph
W	168* mph
Y	186* mph

### Speed Rating

The speed rating denotes the speed at which a tire is designed to be driven for extended periods of time. The ratings range from 99 miles per hour (mph) to 186 mph. These ratings are listed below. Note: You may not find this information on all tires because it is not required by law.

\* For tires with a maximum speed capability over 149 mph, tire manufacturers sometimes use the letters ZR. For those with a maximum speed capability over 186 mph, tire manufacturers always use the letters ZR.

### U.S. DOT Tire Identification Number

This begins with the letters "DOT" and indicates that the tire meets all federal standards. The next two numbers or letters are the plant code where it was manufactured, and the last four numbers represent the week and year the tire was built. For example, the numbers 3197 means the 31st week of 1997. The other numbers are marketing codes used at the manufacturer's discretion. This information is used to contact consumers if a tire defect requires a recall.

### Tire Ply Composition and Materials Used

The number of plies indicates the number of layers of rubber-coated fabric in the tire. In general, the greater the number of plies, the more weight a tire can support. Tire manufacturers also must indicate the materials in the tire, which include steel, nylon, polyester, and others.

### Maximum Load Rating

This number indicates the maximum load in kilograms and pounds that can be carried by the tire.

### Maximum Permissible Inflation Pressure

This number is the greatest amount of air pressure that should ever be put in the tire under normal driving conditions.

### 1.6.9.2. UTQGS Information

#### **Treadwear Number**

This number indicates the tire's wear rate. The higher the treadwear number is, the longer it should take for the tread to wear down. For example, a tire graded 400 should last twice as long as a tire graded 200.

#### **Traction Letter**

This letter indicates a tire's ability to stop on wet pavement. A higher graded tire should allow you to stop your car on wet roads in a shorter distance than a tire with a lower grade. Traction is graded from highest to lowest as "AA", "A", "B", and "C".

#### **Temperature Letter**

This letter indicates a tire's resistance to heat. The temperature grade is for a tire that is inflated properly and not overloaded. Excessive speed, underinflation or excessive loading, either separately or in combination, can cause heat build-up and possible tire failure. From highest to lowest, a tire's resistance to heat is graded as "A", "B", or "C".

### 1.6.9.3. Additional Information on Light Truck Tires

Please refer to the following diagram.



Tires for light trucks have other markings besides those found on the sidewalls of passenger tires.

**LT** - The "LT" indicates the tire is for light trucks or trailers.

**ST** - An "ST" is an indication the tire is for trailer use only.

#### **Max. Load Dual kg (lbs) at kPa (psi) Cold**

This information indicates the maximum load and tire pressure when the tire is used as a dual, that is, when four tires are put on each rear axle (a total of six or more tires on the vehicle).

#### **Max. Load Single kg (lbs) at kPa (psi) Cold**

This information indicates the maximum load and tire pressure when the tire is used as a single.

## **Load Range**

This information identifies the tire's load-carrying capabilities and its inflation limits.

### **1.7. Tire Safety Tips**

#### **Preventing Tire Damage**

- Slow down if you have to go over a pothole or other object in the road.
- Do not run over curbs or other foreign objects in the roadway, and try not to strike the curb when parking.

#### **Tire Safety Checklist**

- Check tire pressure regularly (at least once a month), including the spare.
- Inspect tires for uneven wear patterns on the tread, cracks, foreign objects, or other signs of wear or trauma.
- Remove bits of glass and foreign objects wedged in the tread.
- Make sure your tire valves have valve caps.
- Check tire pressure before going on a long trip.
- Do not overload your vehicle. Check the Tire Information and Loading Placard or User's Manual for the maximum recommended load for the vehicle.

# ***Activate your Load Rite Warranty***

**Visit [www.loadrite.com](http://www.loadrite.com) to register  
your warranty with Load Rite.**

## WARRANTY INFORMATION

If you experience any difficulties or defects with parts of the trailer, please look for the manufacturer's name on the part and contact them directly. The following is a list of Load Rite's current vendors from whom parts are purchased:

<b>Vendor</b>	<b>Part Description</b>	<b>Phone Number</b>
C.H. Yates Rubber Corp.	Rubber Rollers	1-508-674-3378
Cequent Electrical Products	Wire Harnesses	1-800-786-7968
Cequent Trailer Products	Plastic Fenders	1-715-693-1700
Dutton-Lainson	Tongue Jack, Couplers, Winches	1-402-462-4141
Kenda / LOADSTAR	Tires	1-800-225-4714
Petersen	Incandescent Lights, LED Lights	1-800-821-3490
Peerless Chain	Safety Chains	1-800-533-8056
Reliable Tool & Machine	Torsion Axles	1-260-347-4000
Tie Down Engineering	Torsion Axles, Brakes (disc & drum), Actuators, Safety Cables, Aluminum Fenders	1-800-241-1806
Titan International	Actuators	1-800-872-2327

**LOAD RITE Trailers, Inc.**  
265 Lincoln Highway  
Fairless Hills, PA 19030  
215-949-0500