

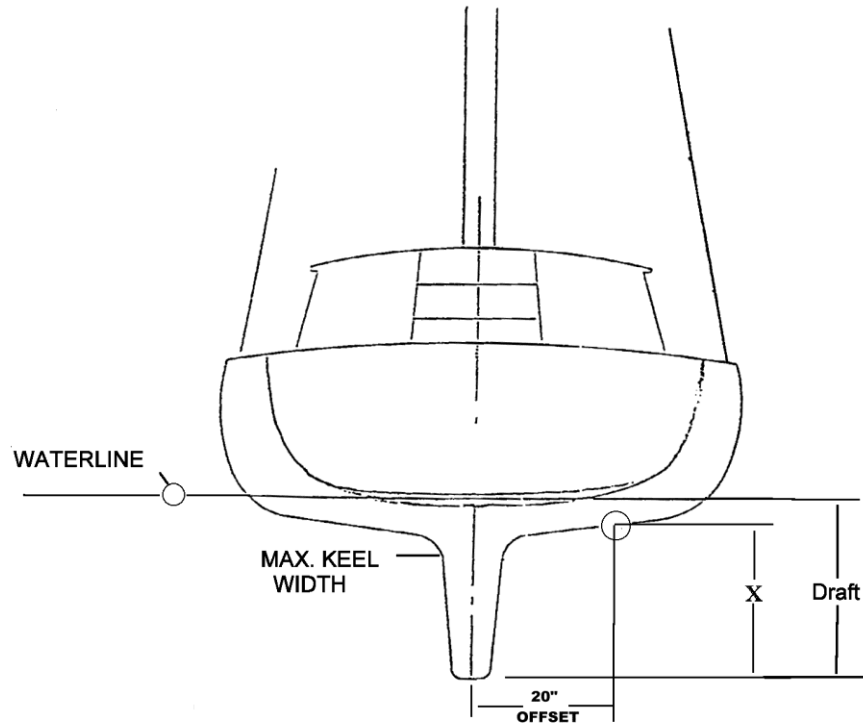

If you have a requirement for a sailboat trailer, the following form must be completed to assess modifications that may have to be made to our standard product line to service your needs. There will be a small up-charge for providing this service.



Boat Type (Make) -- _____

Length (Bow eye- Transom) -- _____

Weight of Boat (Rigged) - _____

*Keel Type - [1] Fixed - Full or Fin [2] Swing - weighted [3] Keel Centerboard [4] Wing

"X" - _____

Keel Width - _____

Draft - _____

Beam - _____

MAIN PLANT
265 Lincoln Highway
Fairless Hills, PA 19030-1193
215-949-0500 215-949-1385
800-562-3783

OUR WEB ADDRESS IS
www.loadrite.com

SOUTHEAST PLANT
Flanders Filters Rd, Route 3 • BOX 26
Washington, NC 27889
919-975-7395 FAX 919-975-2185
800-288-6884