

# Instructions for Bleeding Tie Downs Model 66, 70 & 80 Actuators

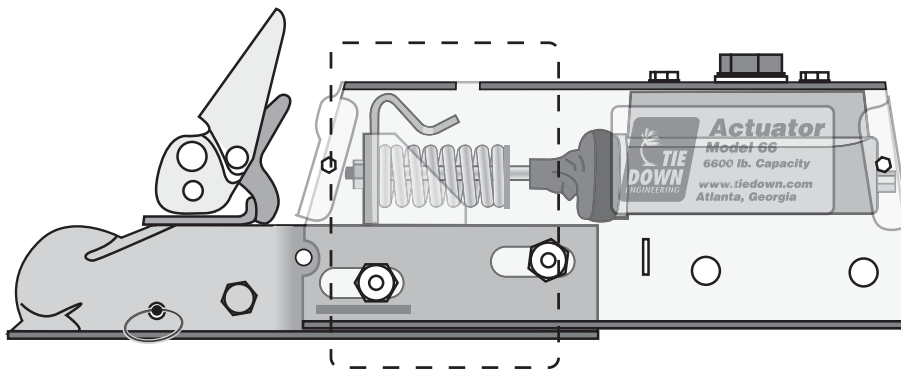

Tie Down's actuators feature a shock dampener that uses brake fluid from the master cylinder. The dampener must be primed before bleeding or using trailer. To prime the dampener, fill the master cylinder with DOT 3 brake Fluid. Push the coupler into the housing and slowly pull out 3 times, then refill master cylinder.

To pump master cylinder, insert a flat tip screwdriver into the round hole near the front of the actuator cover. (picture 1) Screwdriver tip will fit into the slot provided in the emergency brake bracket as shown. Push the screwdriver forward and back to pump the master cylinder. (picture 2).

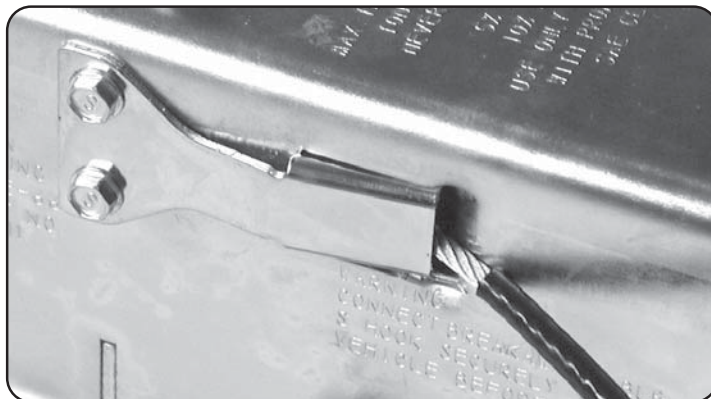
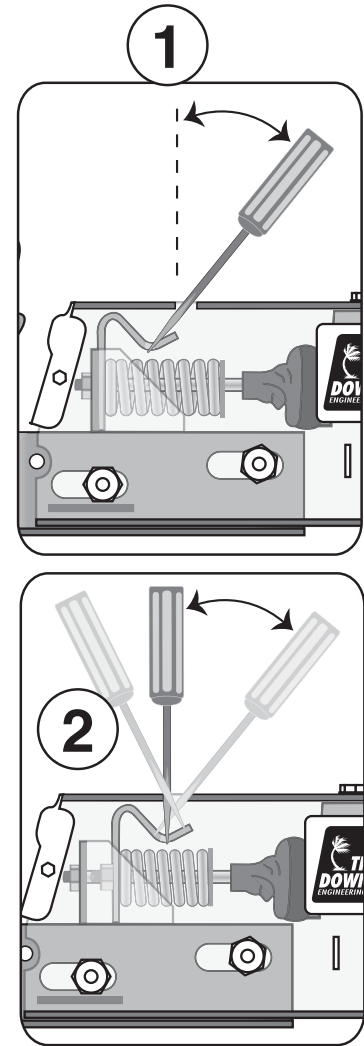

## Normal Operation

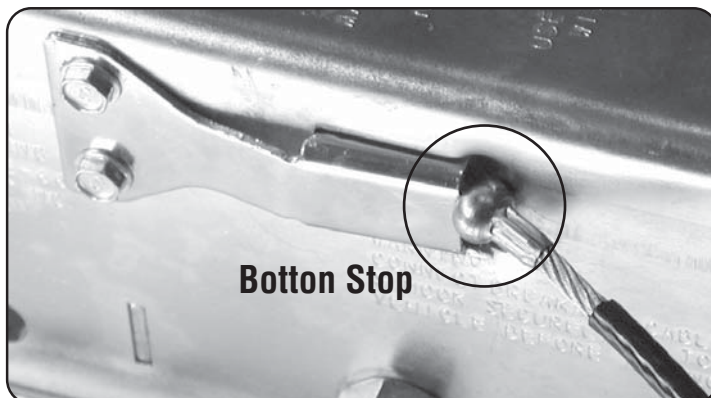

Botton Stop

## Emergency Stop Position

**WARNING:** If button stop cable is showing  
**DO NOT TOW TRAILER**

Release emergency stop cable by prying  
spring out with a flat blade screw driver.